



CHARACTERISTIC OF FLOODED RECHARGEABLE LEAD ACID BATTERY

MODEL: 12N24-4A

NO.:301020003-00149



Plane Chart:

Unit:mm Terminal type:G6

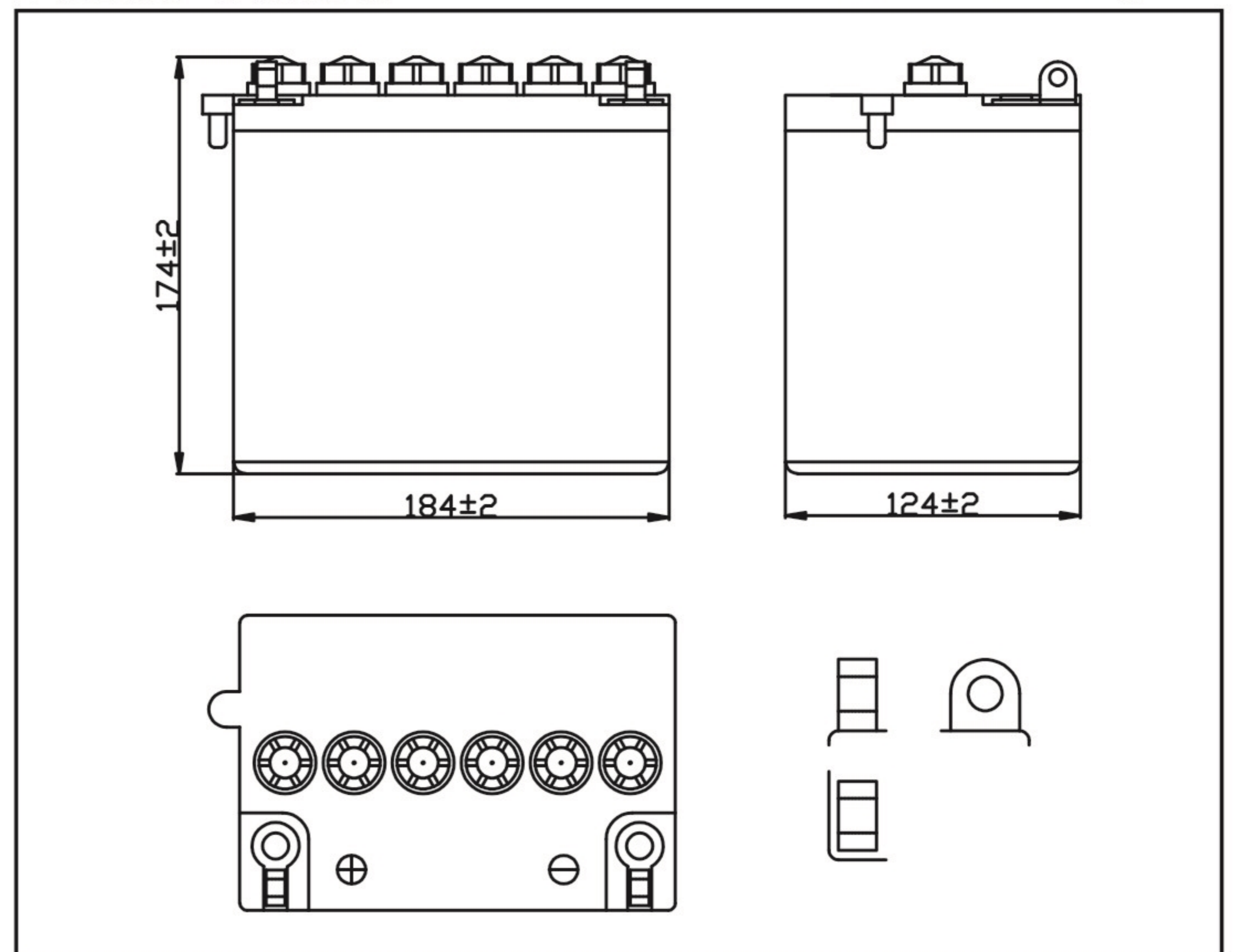

Parts:

Executed Standard:JISD 5302-2004

Cover	Container Bottom	Terminal	Positive Plate	Negative Plate	Separator	Electrolyte	Safety Valve	Explosion Plate	Way of Sealing
PP	PP	Pb	PbO ₂	Pb	PE/Compound Fibre	dilute sulphuric acid	Rubber	PP	Heat Sealing

Parameter Chart:

Volts	12V	
Capacity (25°C)	10 hours rate	24Ah
Appx.Dimension (mm)	L±2	184
	W±2	124
	H±2	174
Storage Status	Dry	
Weight (Approx)	4.9Kg	Weight w/ Acid 2.58Kg
Retention of Charge Storage @25°C		
1 month	97%	Directly Mounted
3 month	90%	Directly Mounted
6 month	80%	Constant Volts:14.4V Limit Current:4.8A Charging Hours:2-3H
12 month	40%	Constant Volts:14.4V Limit Current:4.8A Charging Hours:4-6H
CCA	Factory Standard (-10°C)	Factory Standard (-18°C)
Discharging Current	192A	250A

Discharge Current 25°C

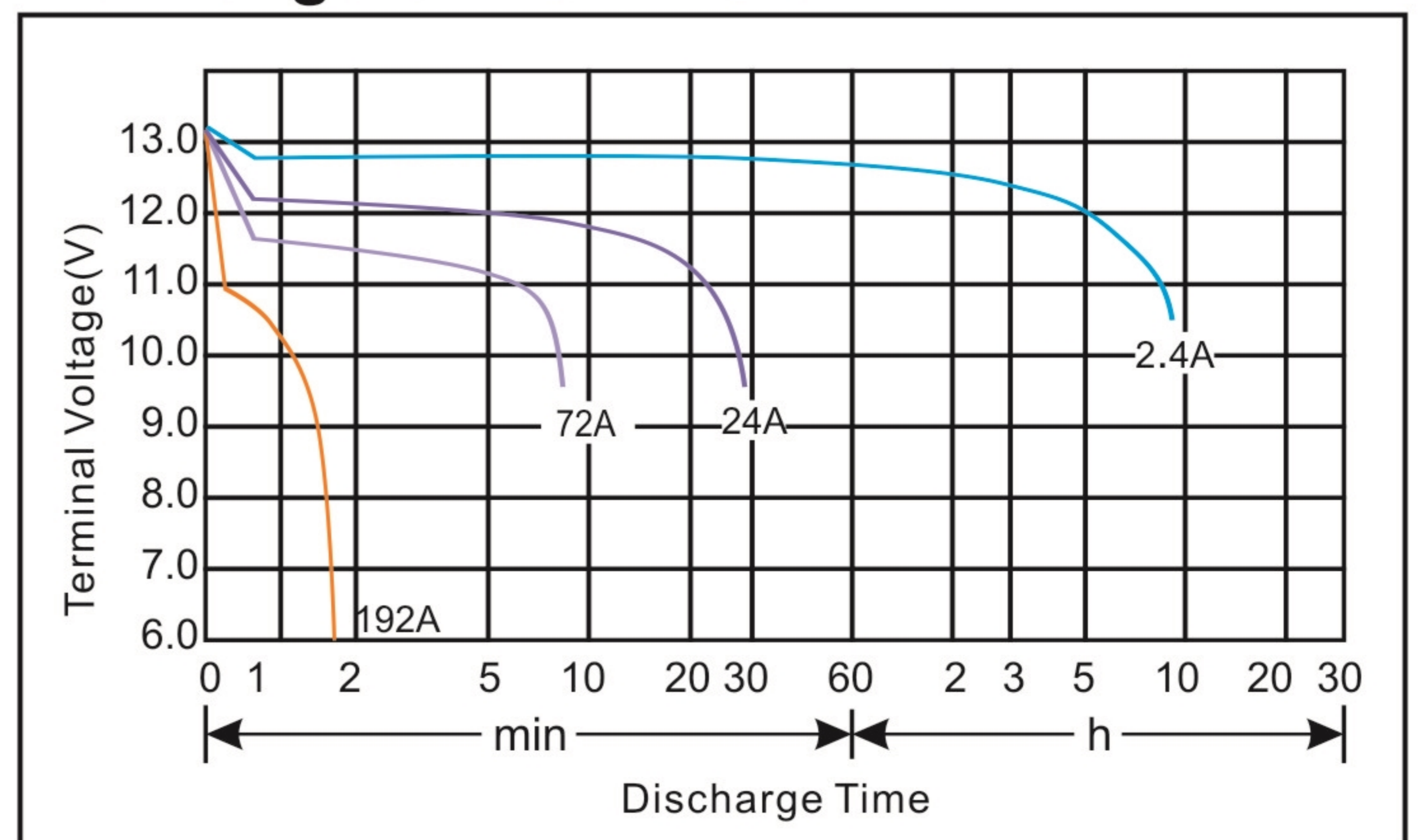

Residual Capacity

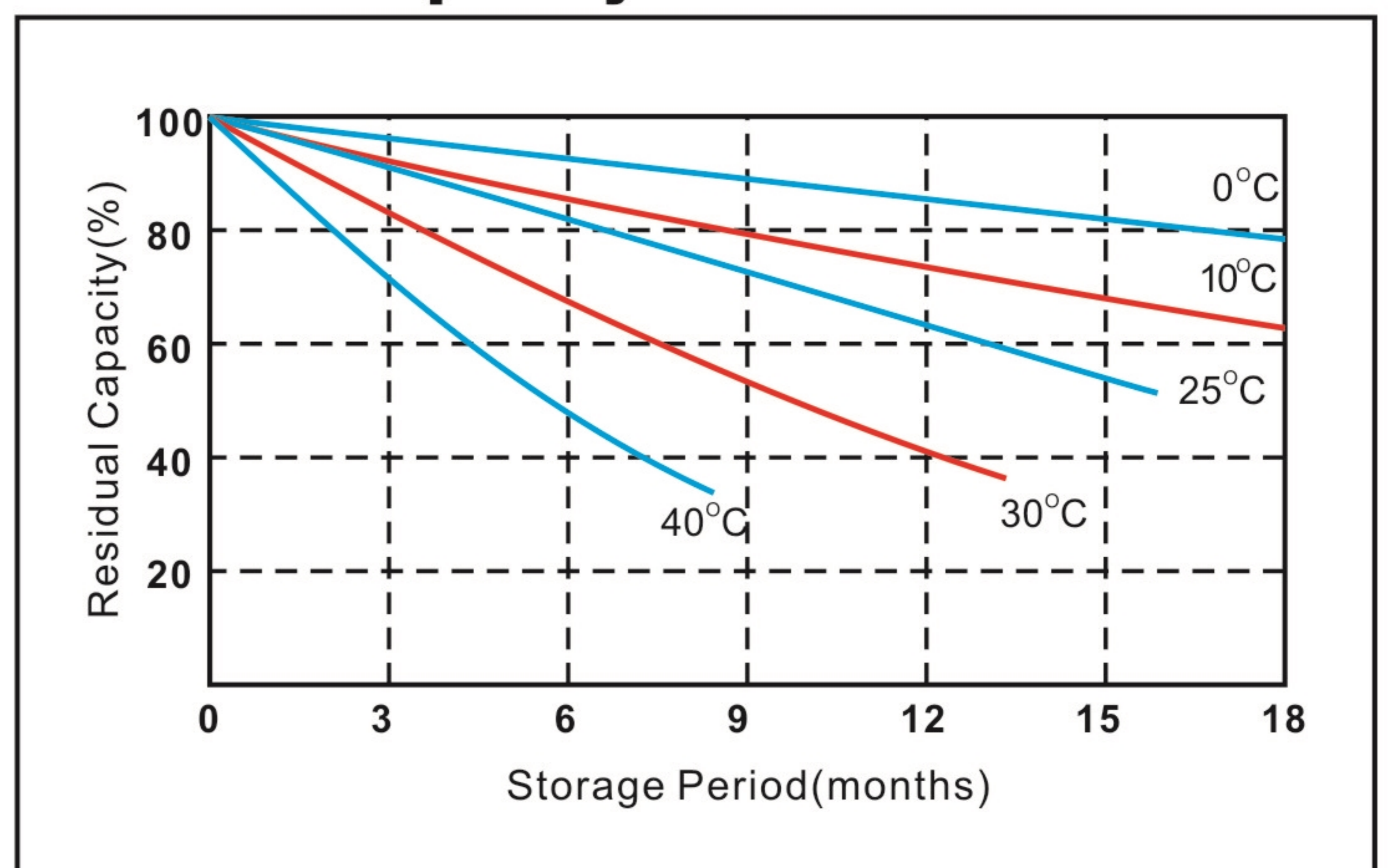

★The above are average and data obtained from the first 3 charge/discharge cycles. These are not minimum values.

★The different item No. of battery can be developed according to the customer's demand.